

- ALL STEEL CONSTRUCTION
- FITS STANDARD 2' X 2' T-BAR CEILING SYSTEMS
- AVAILABLE IN 6-14 INCH FIXED COLLAR SIZES
- REMOVABLE FACE PLATE
- USE NO. 3800 STEEL BUTTERFLY DAMPER (PLATE MUST BE REMOVED)
- 360° PATTERN DELIVERY
- FINISH: WHITE (W) ENAMEL

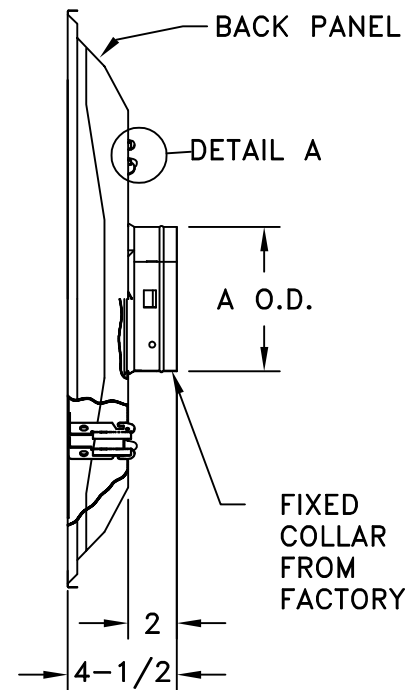
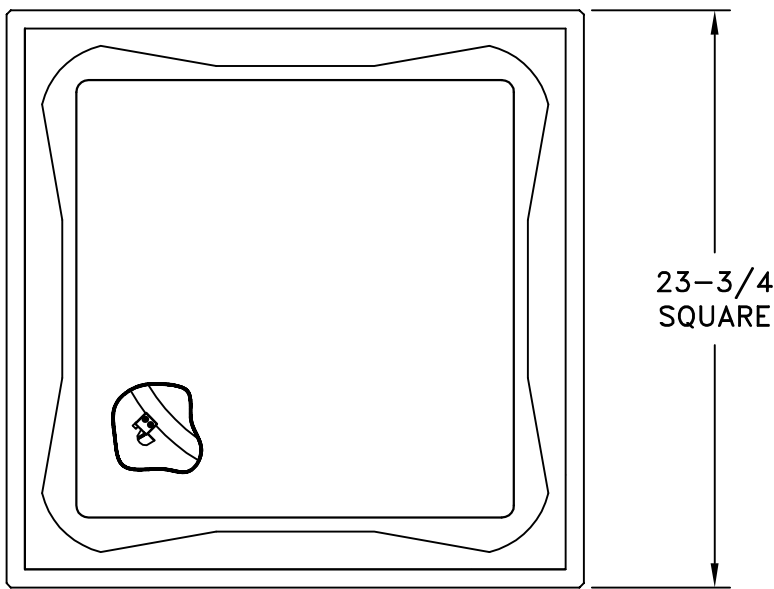

REMOVING FACE PLATE:

1. REMOVE BLACK PUSH PINS FROM HOOKS.
2. PUSH THE FACE PLATE TOWARDS THE BACK PANEL. THIS WILL DIS-ENGAGE THE HOOKS FROM THE BACKSIDE PANEL SLOTS (DETAIL A).
3. ROTATE THE FACE PLATE COUNTER-CLOCKWISE AND PULL PLATE AWAY FROM BACK PANEL AND HOOKS THRU THE SLOTS.

SIZE	A O.D.
6	5-7/8
8	7-7/8
10	9-7/8
12	11-7/8
14	13-7/8

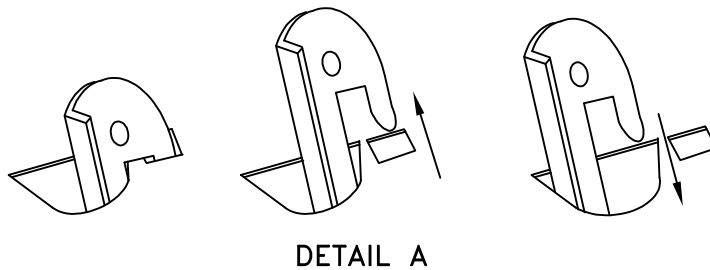

JOB NAME: _____	SUBMITTED BY: _____	DATE: 07/17/2013	SD-9438
LOCATION: _____		DPD Steel Detachable Plate Diffuser	
ARCHITECT: _____			
ENGINEER: _____			
CONTRACTOR: _____			