

- ALUMINUM FACE, PAINTED STEEL OPPOSED BLADE DAMPER
- ADJUSTABLE VERTICAL FRONT FINNS
- MINIMUM SIZE = 6 X 6
- MAXIMUM SIZE = 14 X 14
- FINISH: WHITE (W) ENAMEL
- USE FLAT BLADE SCREWDRIVER TO ADJUST DAMPER

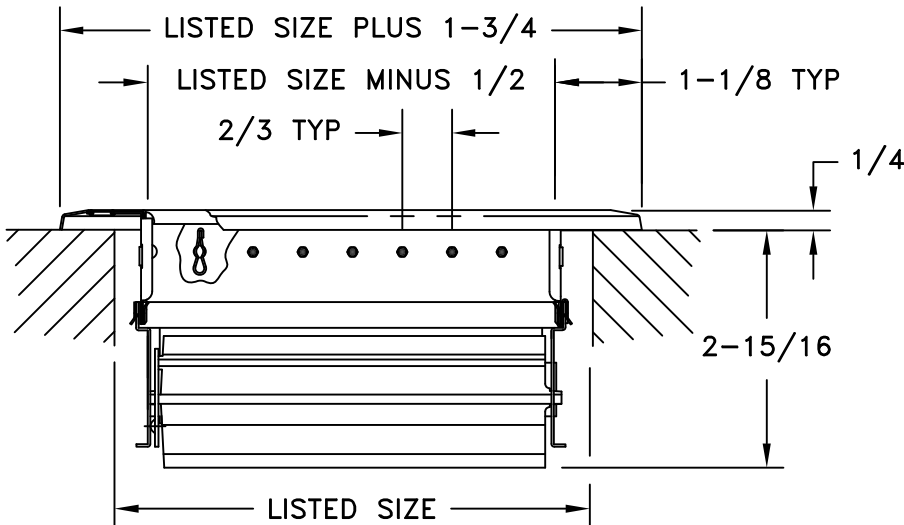
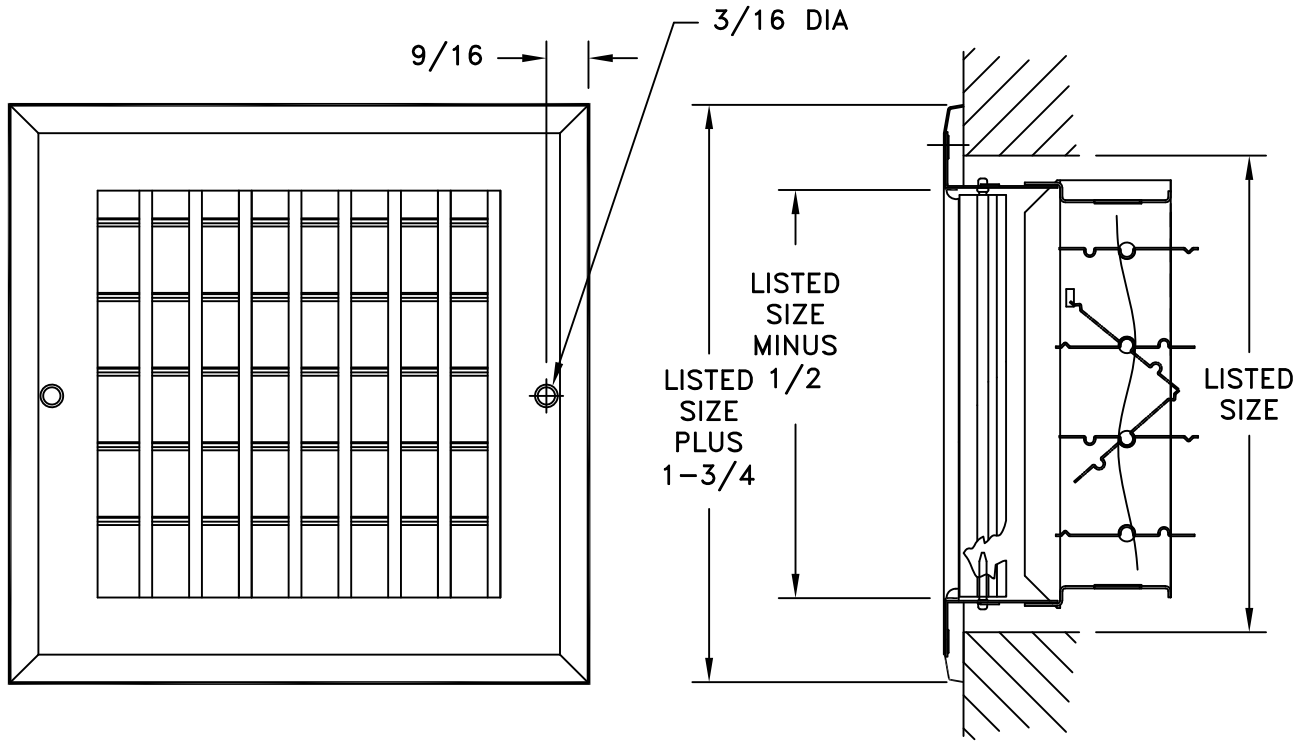

JOB NAME: _____
 LOCATION: _____
 ARCHITECT: _____
 ENGINEER: _____
 CONTRACTOR: _____

SUBMITTED BY: _____

DATE: 07/30/2024 SD-2510
A618-OB
 Aluminum, Adjustable Straight Fin
 Register With Painted Steel
 Opposed Blade Damper
 Single Deflection