

- EXTRUDED ALUMINUM CONSTRUCTION
- PERMANENT HINGE DESIGN, 1/4 TURN LATCH FASTENERS
- USES NOMINAL 1 INCH DISPOSABLE FILTERS
- FILTER SIZE EQUALS LISTED SIZE MINUS 1/4 INCH
- SIZES: 20 X 20, 44 X 20
- FINISH: WHITE (W) ENAMEL OR MILL

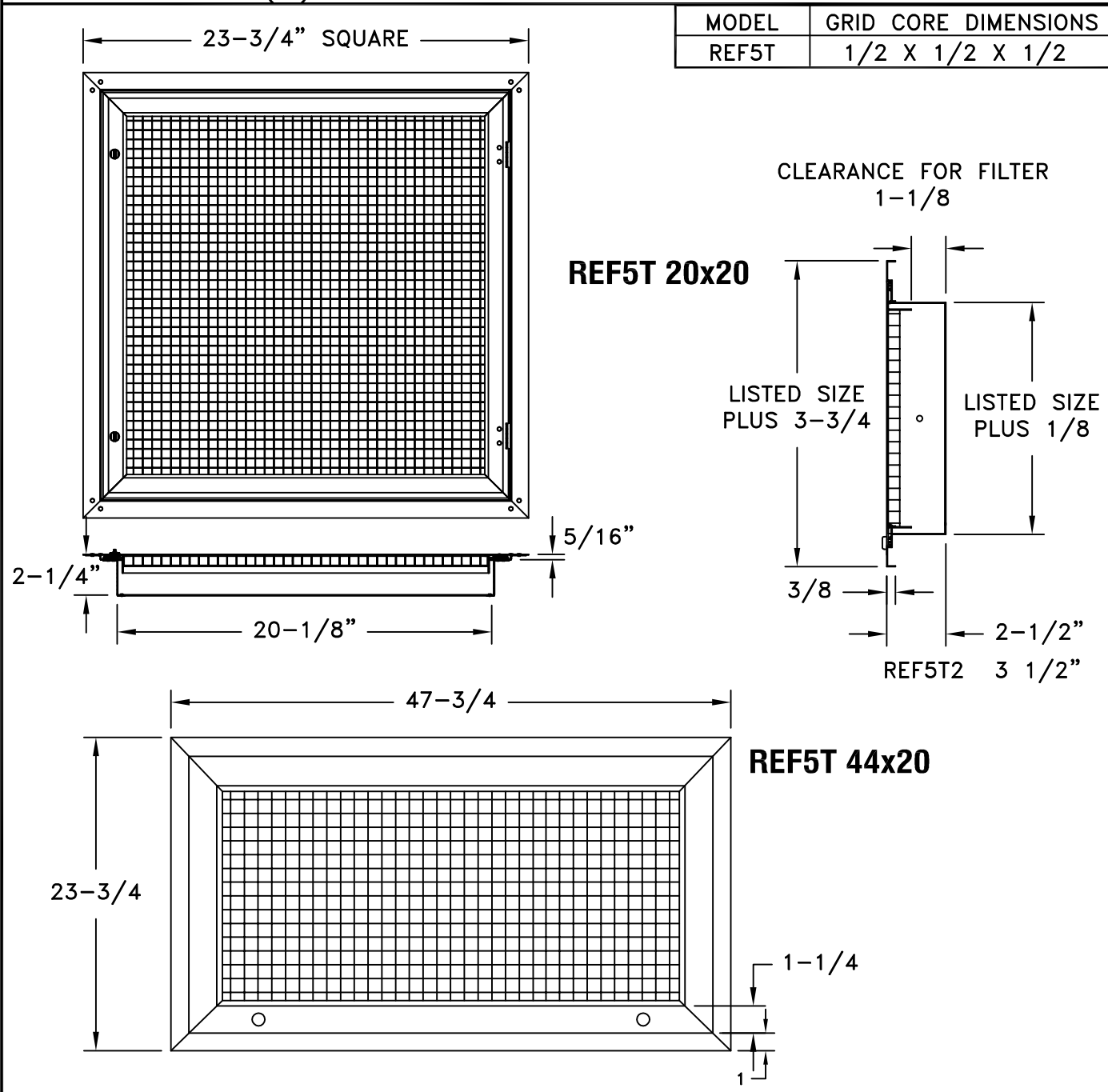

JOB NAME: _____	SUBMITTED BY: _____	DATE: 12/11/2020	SD-9482
LOCATION: _____		REF5T Extruded Aluminum Grid Core T-Bar Filter Grille	
ARCHITECT: _____			
ENGINEER: _____			
CONTRACTOR: _____			