

- ALL STEEL CONSTRUCTION
- FITS STANDARD 12" X 12" T-BAR CEILING SYSTEMS
- AVAILABLE IN 6,7,8 INCH FIXED COLLAR SIZES
- REMOVABLE FACE PLATE
- 360° PATTERN DELIVERY
- FINISH: WHITE (W) ENAMEL

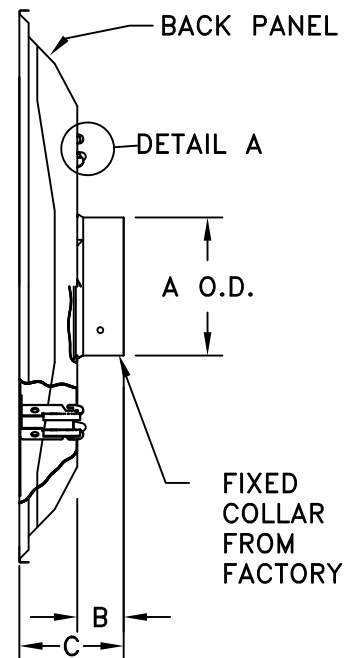

### REMOVING FACE PLATE:

1. PUSH THE FACE PLATE TOWARDS THE BACK PANEL. THIS WILL DISENGAGE THE HOOKS FROM THE BACKSIDE PANEL SLOTS (DETAIL A).
2. ROTATE THE FACE PLATE COUNTER-CLOCKWISE AND PULL PLATE AWAY FROM BACK PANEL AND HOOKS THRU THE SLOTS.

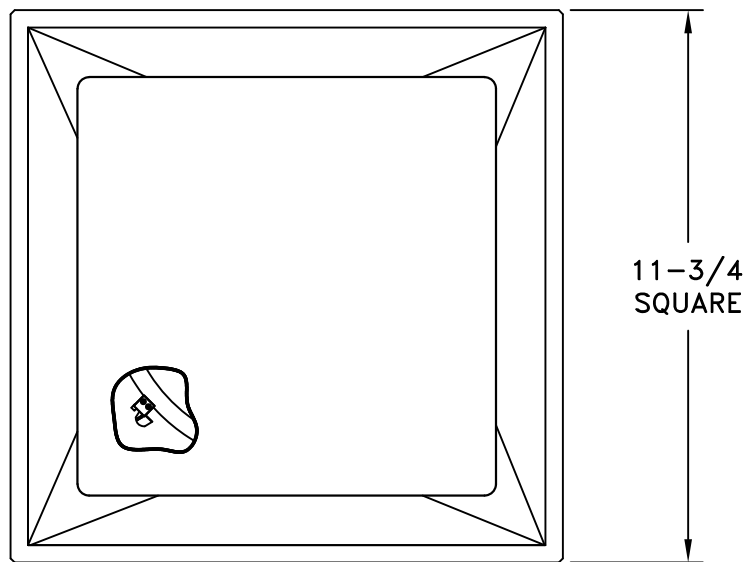
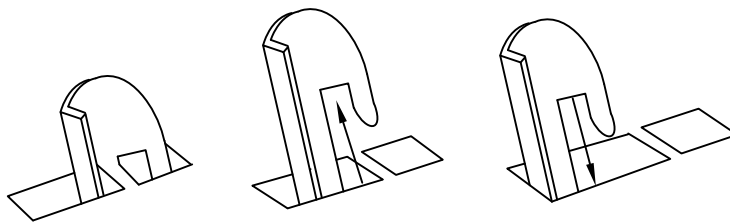

DETAIL A

SIZE	A O.D.	B	C
6	5-7/8	1 1/8	2 1/4
7	6-7/8	1 1/8	2 1/4
8	7-7/8	1 1/4	2 3/8

JOB NAME: _____	SUBMITTED BY: _____	DATE: 07/24/2024	SD-9456
LOCATION: _____	<b>DPD12</b> Steel Detachable Plate Diffuser		
ARCHITECT: _____			
ENGINEER: _____			
CONTRACTOR: _____			